

DESCRIPTION

Cylinders series "B" are widely used in locking applications thanks to compact design and to easy mounting through holes on cylinder body. In the version with magnetic piston type, cylinders series "B" are supplied with magnetic sensors.

TECHNICAL DATA

Operating pressure	1 ÷ 10 bar
Working temperature	0 ÷ +80 °C (-20 °C with dry air) 0 ÷ +150 °C with seals for high temperatures (-10 °C with dry air)
Fluid	Filtered, unlubricated or continuous lubricated compressed air
Versions	Double acting; Single acting front spring; Single acting rear spring; Through rod; Non-rotating piston rod device.
Bore	Ø 12, 16, 20, 25, 32, 40, 50, 63, 80, 100
Port size	Ø 12 ÷ 20 = M5 Ø 25 ÷ 63 = G 1/8 Ø 80 - 100 = G 1/4
Standard strokes	See tables

MATERIALS

Front end cap	Ø 12 ÷ 25: Brass Ø 32 ÷ 100: Aluminium
Rear end cap	Anodized aluminium alloy
Cylinder barrel	Extruded profile, 15 µm anodized aluminium alloy
Piston rod	AISI 303 stainless steel
Piston rod bearing	Bronze + PTFE
Piston	Ø 12 ÷ 32: Delrin (supplied with and without magnet) Ø 40 ÷ 100: Aluminium (supplied with and without magnet)
Seals	Ø 12 ÷ 32: NBR rubber Ø 40 ÷ 100: Polyurethane Ø 12 ÷ 100: Viton®
Cushioning washer	Vulkollan
Spring	AISI 303 stainless steel

ORDER KEY

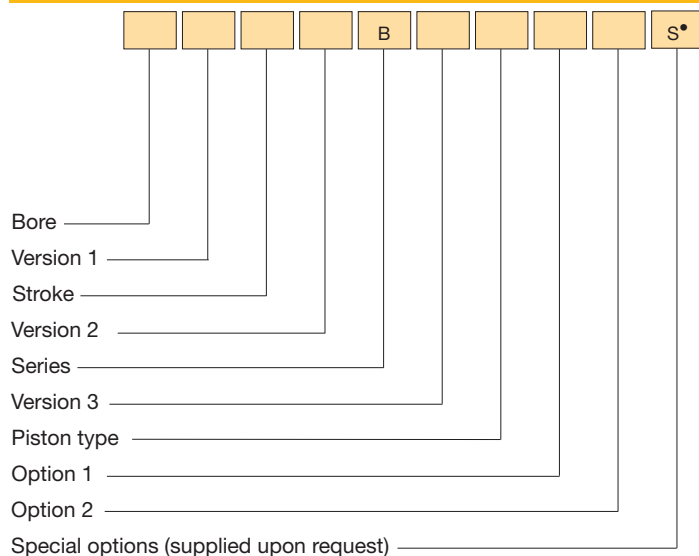

P.S.: *Magnetic sensors* FM 100 (see chapter magnetic sensors from page 1.93)

• See technical data on page 0.12

ORDER EXAMPLES

Basic cylinder Ø16, 50 mm stroke, double acting, non-magnetic piston type 16/50 DB

Basic cylinder Ø20, 60 mm stroke, double acting, non-magnetic piston type, seals for high temperatures 20/60 DB2

Cylinder Ø32, through rod, 80 mm stroke, double acting, magnetic piston type 32R80 DB/M

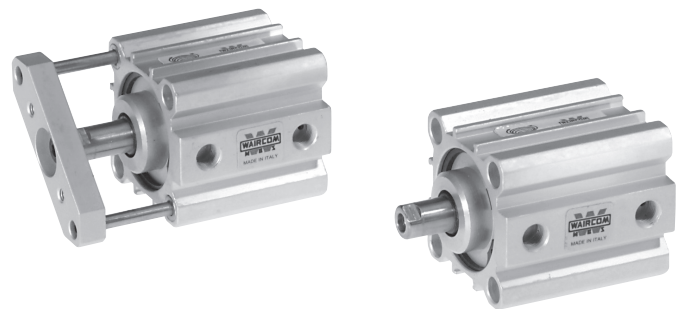

SPRING THEORETICAL TRACTIVE FORCE

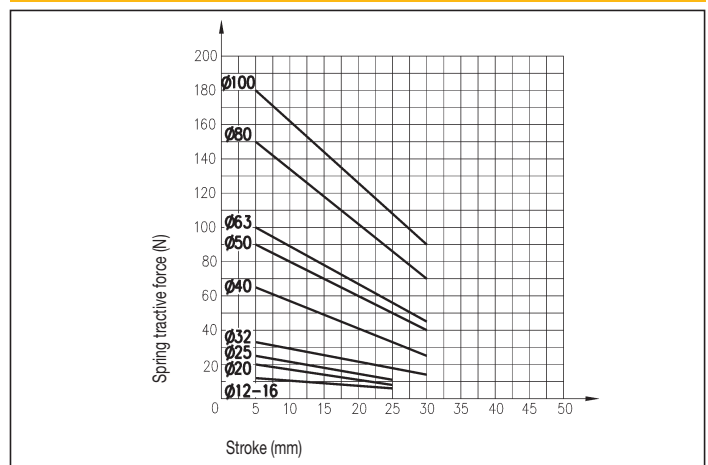

VERSION 1

/ Basic cylinder **R** Through rod

VERSION 2

D Double acting **Y** Single acting rear spring
S Single acting front spring

VERSION 3

A Non-rotating piston rod device*

PISTON TYPE

Non-magnetic **/M** Magnetic

OPTION 1

1 Male hinge mounting

OPTION 2

2 Seals for high temperatures

* Supplied only from Ø 20 to Ø 100

SPARE PARTS

Contact the commercial office

SINGLE AND DOUBLE ACTING

1

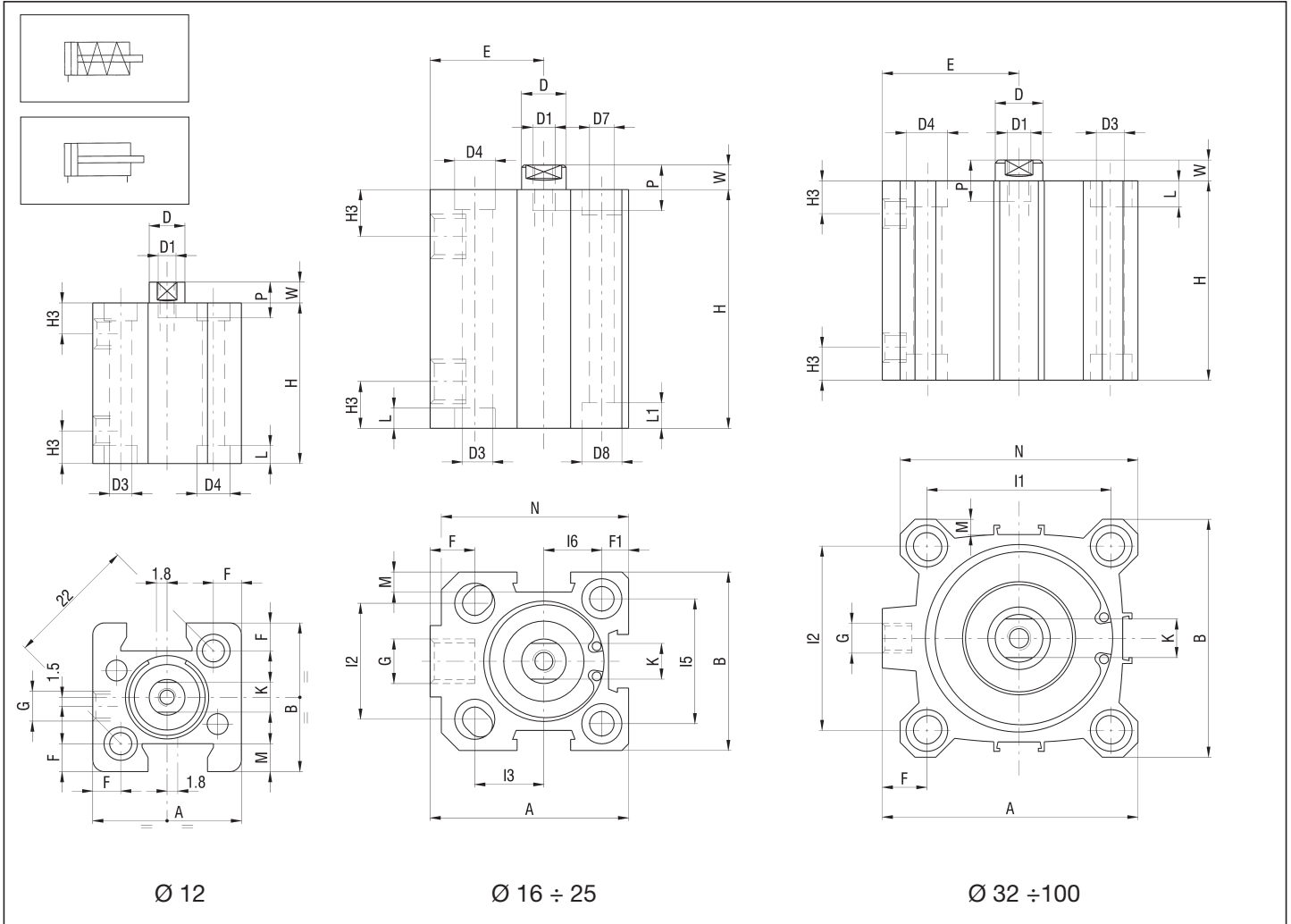

DIMENSIONS AND WEIGHTS

Ø	A	B	D	D1	D3	D4	D7	D8	E	F	F1	G	H3	I1	I2	I3	I5	I6	K	L	L1	M	N	P	W	WEIGHT (g)	INCR. (g) x10 mm
12	25	25	6	M3	3,7	5,6	-	-	-	4,7	-	M5	5,5	-	-	-	-	5	3,5	-	4,7	-	6	3,5	33,5	11,5	
16	34	30	8	M4	4,7	7,5	3,7	5,6	19	7	5	M5	8	-	18	12	20	10	6	4,6	3,5	4	32	8	4,5	74	16,5
20	40	36	10	M5	5,8	9	5,8	9	22	7	5,2	M5	8	-	20	15	25,5	12,7	8	5,7	5,7	5,7	38,5	10	5	106	24,5
25	44,5	40	10	M5	5,8	9	5,8	9	24,5	9	6	G 1/8	10,5	-	26	15,5	28	14	8	5,7	5,7	4,5	42	10	5,5	145	32
32	51	46	12	M6	5,8	9	-	-	27	9	-	G 1/8	11,5	36	32	-	-	10	5,7	-	4	48	12	6	172	36	
40	58	55	12	M6	5,8	9	-	-	30,5	9,5	-	G 1/8	11	42	42	-	-	10	5,7	-	4	55	12	6	225	40	
50	70	65	16	M8	6,8	11	-	-	37,5	12,5	-	G 1/8	11,5	50	50	-	-	13	6,8	-	4	65	12	7,5	359	63	
63	86	80	16	M8	9	14	-	-	46	15	-	G 1/8	11	62	62	-	-	13	8,8	-	5	80	14	7	552	70	
80	105	100	20	M10	9	14	-	-	55	14	-	G 1/4	14	82	82	-	-	17	9	-	6	100	15	8	1072	105	
100	131	124	25	M12	11	17,2	-	-	69	17,5	-	G 1/4	16	103	103	-	-	22	11	-	7,5	124	20	10	1920	160	

"H" DIMENSION-SINGLE ACTING

Ø	STROKE (mm)					
	5	10	15	20	25	30
12	22	27	-	-	-	-
16	32	37	42	47	52	-
20	32	37	42	47	52	-
25	33,5	38,5	43,5	48,5	53,5	-
32	34,5	39,5	44,5	49,5	54,5	59,5
40	34,5	39,5	44,5	49,5	54,5	59,5
50	-	44,5	49,5	54,5	59,5	64,5
63	-	47	52	57	62	67
80	-	56	61	66	71	76
100	-	66	71	76	81	86

"H" DIMENSION-DOUBLE ACTING

Ø	STROKE (mm)										
	5	10	15	20	25	30	40	50	60	80	100
12	22	27	32	37	42	47	57	-	-	-	-
16	32	37	42	47	52	58	68	78	-	-	-
20	32	37	42	47	52	58	68	78	-	-	-
25	33,5	38,5	43,5	48,5	53,5	58,5	69,5	79,5	-	-	-
32	34,5	39,5	44,5	49,5	54,5	59,5	69,5	79,5	89,5	109,5	129,5
40	34,5	39,5	44,5	49,5	54,5	59,5	69,5	79,5	89,5	109,5	129,5
50	-	44,5	49,5	54,5	59,5	64,5	74,5	84,5	94,5	114,5	134,5
63	-	47	52	57	62	67	77	87	97	117	137
80	-	56	61	66	71	76	86	96	106	126	146
100	-	66	71	76	81	86	96	106	116	136	156

DOUBLE ACTING MAGNETIC

1

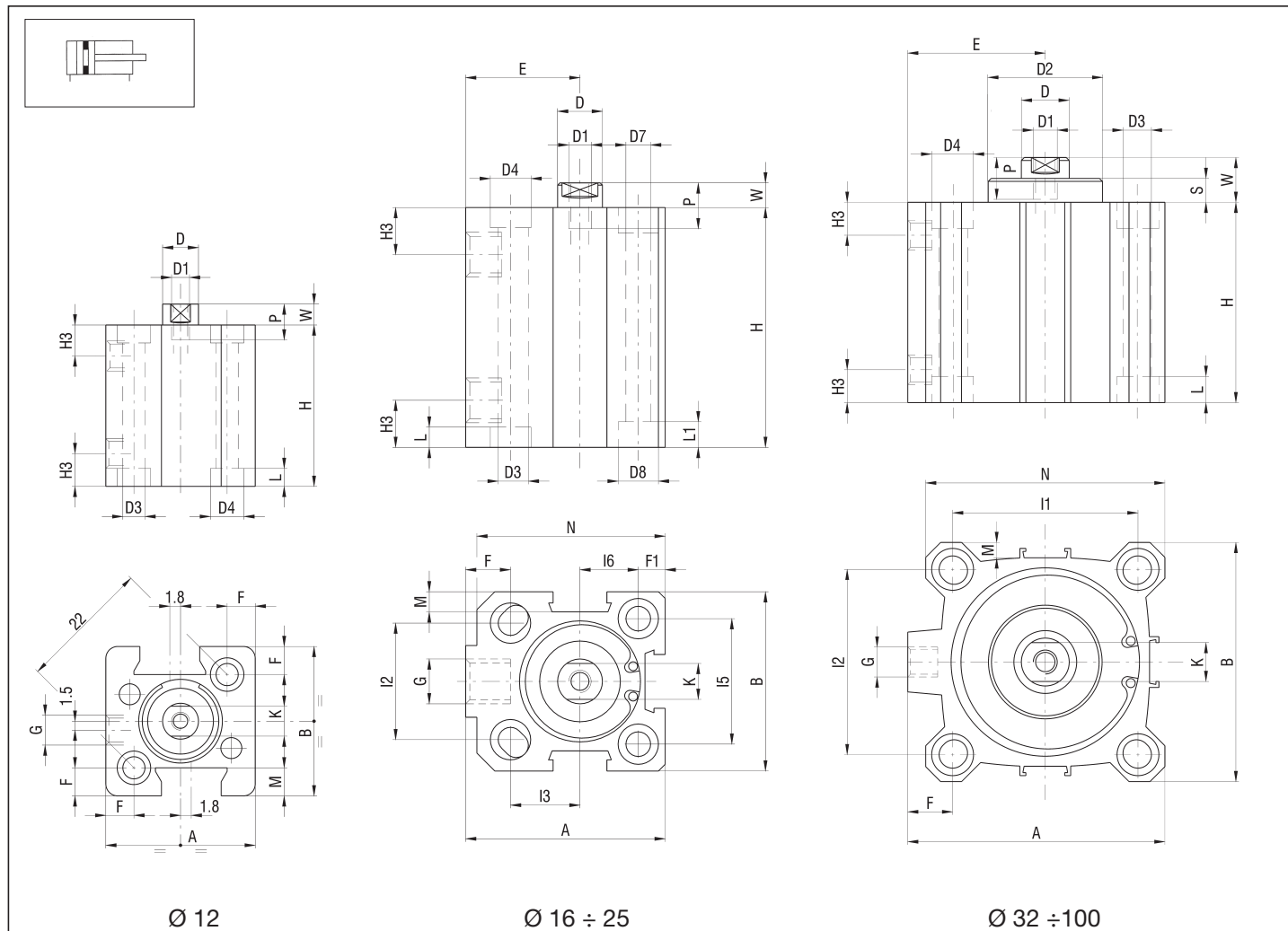

DIMENSIONS AND WEIGHTS

Ø	A	B	D	D1	D2	D3	D4	D7	D8	E	F	F1	G	H3	I1	I2	I3	I5	I6	K	L	L1	M	N	P	S	W	WEIGHT (g)	INCR. (g) x10 mm
12	25	25	6	M3	-	3,7	5,6	-	-	-	4,7	-	M5	5,5	-	-	-	-	5	3,5	-	4,7	-	6	-	3,5	33,5	11,5	
16	34	30	8	M4	-	4,7	7,5	3,7	5,6	19	7	5	M5	8	-	18	12	20	10	6	4,6	3,5	4	32	8	-	4,5	74	16,5
20	40	36	10	M5	-	5,8	9	5,8	9	22	7	5,2	M5	8	-	20	15	25,5	12,7	8	5,7	5,7	5,7	38,5	10	-	5	106	24,5
25	44,5	40	10	M5	-	5,8	9	5,8	9	24,5	9	6	G1/8	10,5	-	26	15,5	28	14	8	5,7	5,7	4,5	42	10	-	5,5	145	32
32	51	46	12	M6	24,5	5,8	9	-	-	27	9	-	G1/8	11,5	36	32	-	-	10	5,7	-	4	48	12	5	11	172	36	
40	58	55	12	M6	28	5,8	9	-	-	30,5	9,5	-	G1/8	11	42	42	-	-	10	5,7	-	4	55	12	6	12,5	225	40	
50	70	65	16	M8	34	6,8	11	-	-	37,5	12,5	-	G1/8	11,5	50	50	-	-	13	6,8	-	4	65	12	6	13,5	359	63	
63	86	80	16	M8	38,5	9	14	-	-	46	15	-	G1/8	11	62	62	-	-	13	8,8	-	5	80	14	7	15	552	70	
80	105	100	20	M10	44	9	14	-	-	55	14	-	G1/4	14	82	82	-	-	17	9	-	6	100	15	8	18	1072	105	
100	131	124	25	M12	56	11	17,2	-	-	69	17,5	-	G1/4	16	103	103	-	-	22	11	-	7,5	124	20	10	20,5	1920	160	

"H" DIMENSION

Ø	STROKE (mm)															
	5	10	15	20	25	30	40	50	60	80	100	125	160	200	250	
12	32	37	42	47	52	57	-	-	-	-	-	-	-	-	-	
16	37	42	47	52	63	68	78	88	98	118	138	-	-	-	-	
20	37	42	47	52	63	68	78	88	98	118	138	163	-	-	-	
25	43,5	48,5	53,5	58,5	64,5	69,5	79,5	89,5	99,5	119,5	139,5	164,5	-	-	-	
32	44,5	49,5	54,5	59,5	64,5	69,5	79,5	89,5	99,5	119,5	139,5	164,5	199,5	-	-	
40	44,5	49,5	54,5	59,5	64,5	69,5	79,5	89,5	99,5	119,5	139,5	164,5	199,5	-	-	
50	-	49,5	54,5	59,5	64,5	69,5	79,5	89,5	99,5	119,5	139,5	164,5	199,5	239,5	-	
63	-	52	57	62	67	72	82	92	102	122	142	167	202	242	-	
80	-	56	61	66	71	76	86	96	106	126	146	171	206	246	296	
100	-	66	71	76	81	86	96	106	116	136	156	181	216	256	306	

SINGLE ACTING, EXTENDED ROD AND SINGLE ACTING MAGNETIC, EXTENDED ROD

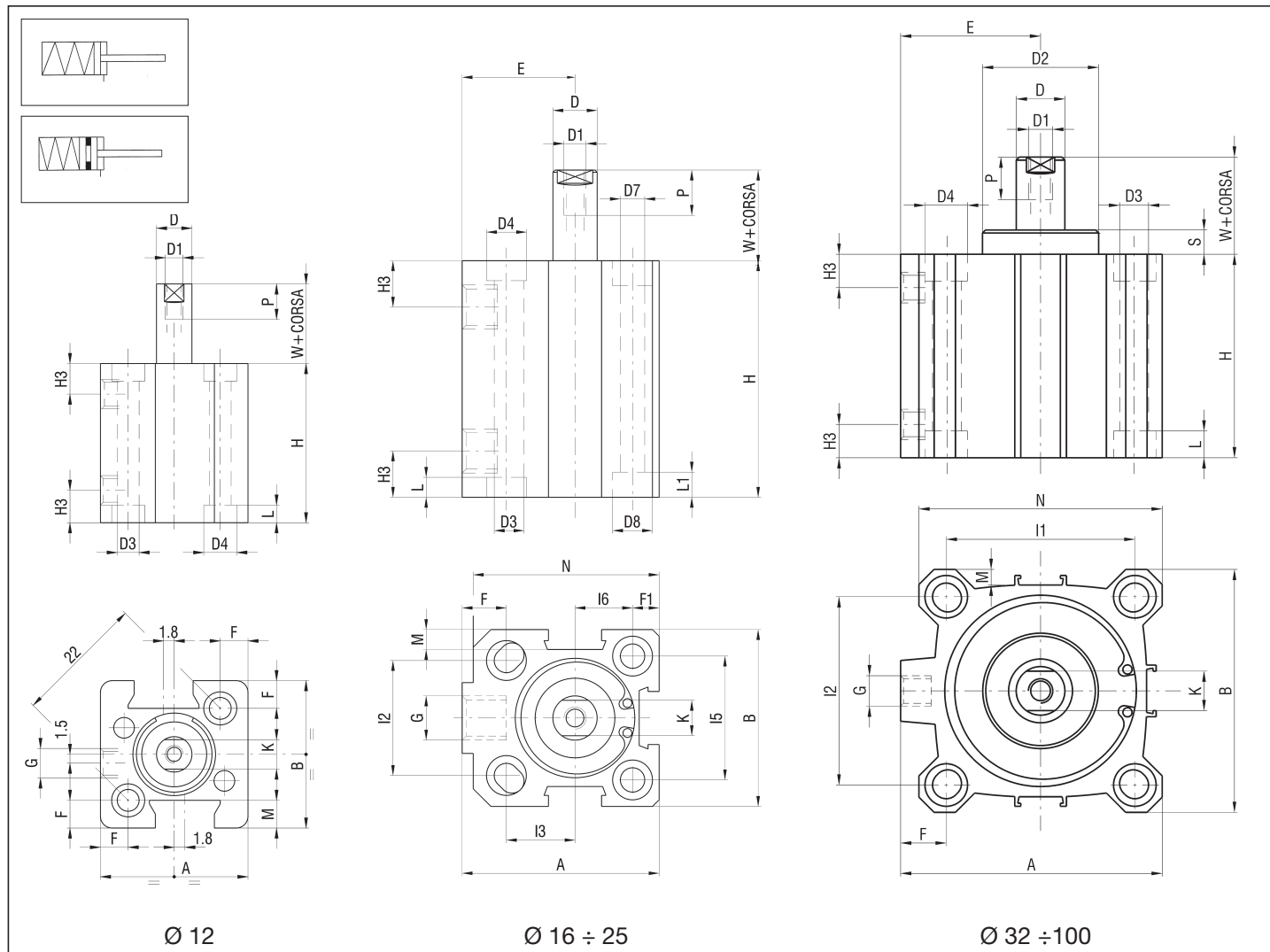

DIMENSIONS AND WEIGHTS

Ø	A	B	D	D1	D2	D3	D4	D7	D8	E	F	F1	G	H3	I1	I2	I3	I5	I6	K	L	L1	M	N	P	S	W	WEIGHT (g)	INCR. (g)
12	25	25	6	M3	-	3,7	5,6	-	-	-	4,7	-	M5	5,5	-	-	-	-	-	5	3,5	-	4,7	-	6	-	3,5	33,5	11,5
16	34	30	8	M4	-	4,7	7,5	3,7	5,6	19	7	5	M5	8	-	18	12	20	10	6	4,6	3,5	4	32	8	-	4,5	74	16,5
20	40	36	10	M5	-	5,8	9	5,8	9	22	7	5,2	M5	8	-	20	15	25,5	12,7	8	5,7	5,7	5,7	38,5	10	-	4,5	106	24,5
25	44,5	40	10	M5	-	5,8	9	5,8	9	24,5	9	6	G 1/8	10,5	-	26	15,5	28	14	8	5,7	5,7	4,5	42	10	-	5,5	145	32
32	51	46	12	M6	24,5	5,8	9	-	-	27	9	-	G 1/8	11,5	36	32	-	-	10	5,7	-	4	48	12	5	11	172	36	
40	58	55	12	M6	28	5,8	9	-	-	30,5	9,5	-	G 1/8	11	42	42	-	-	10	5,7	-	4	55	12	6	12,5	225	40	
50	70	65	16	M8	34	6,8	11	-	-	37,5	12,5	-	G 1/8	11,5	50	50	-	-	13	6,8	-	4	65	12	6	13,5	359	63	
63	86	80	16	M8	38,5	9	14	-	-	46	15	-	G 1/8	11	62	62	-	-	13	8,8	-	5	80	14	8	15	552	70	

"H" DIMENSION

Ø	STROKE (mm)						
		5	10	15	20	25	30
12	-	22	27	-	-	-	-
-	12 magn	32	37	-	-	-	-
16	16 magn	37	42	47	-	-	-
20	20 magn	37	42	47	63	68	-
25	25 magn	43,5	48,5	53,5	64,5	69,5	-
32	32 magn	44,5	49,5	54,5	64,5	69,5	79,5
40	40 magn	-	49,5	54,5	59,5	64,5	69,5
50	50 magn	-	49,5	54,5	59,5	64,5	69,5
63	63 magn	-	52	57	62	67	72

DOUBLE ACTING, THROUGH ROD AND DOUBLE ACTING MAGNETIC, THROUGH ROD

1

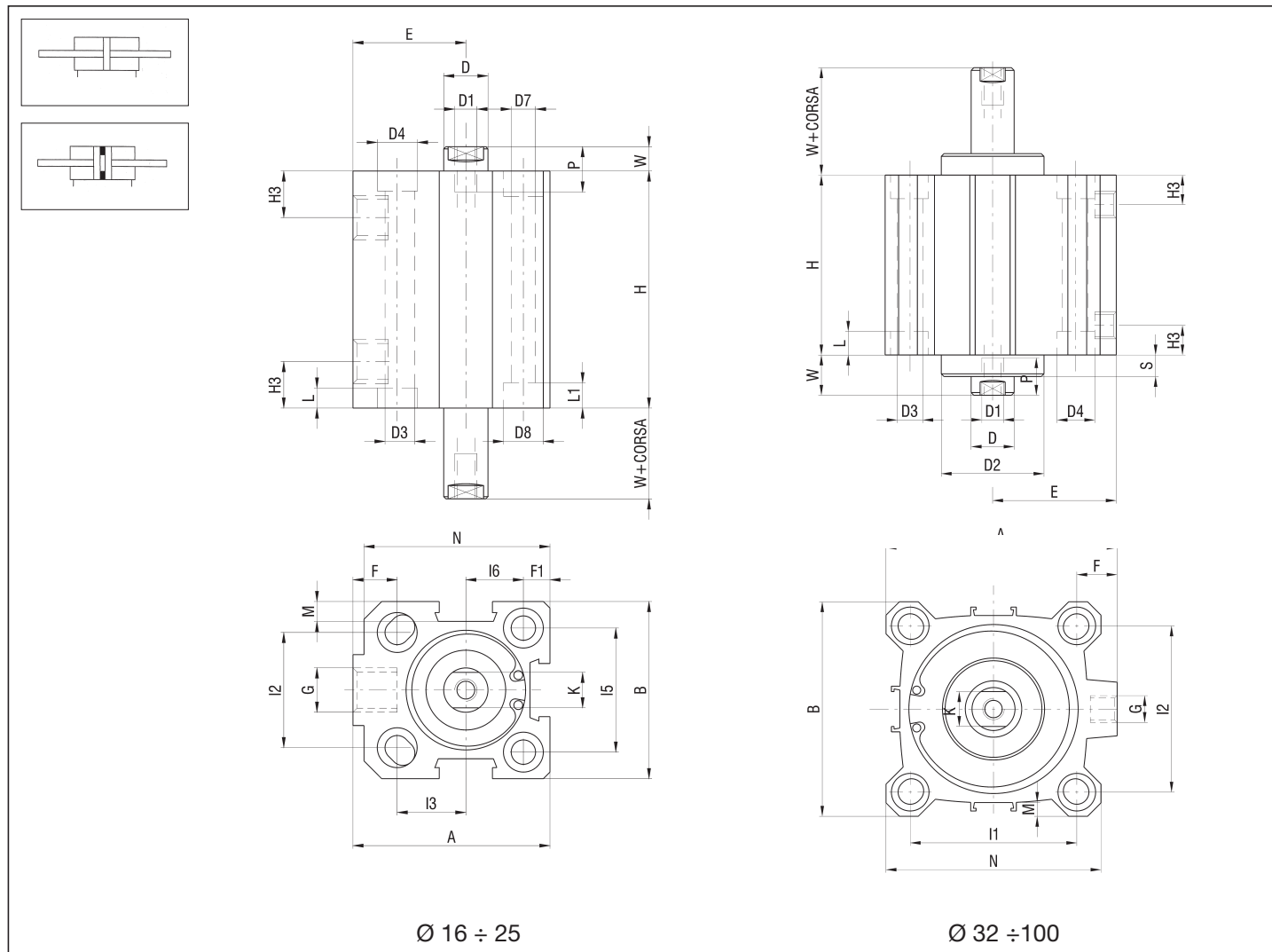

DIMENSIONS AND WEIGHTS

Ø	A	B	D	D1	D2	D3	D4	D7	D8	E	F	F1	G	H3	I1	I2	I3	I5	I6	K	L	L1	M	N	P	S	W	WEIGHT INCR. (g) x 10mm	
16	34	30	8	M4	-	4,7	7,5	3,7	5,6	19	7	5	M5	8	-	18	12	20	10	6	4,6	3,5	4	32	8	-	4,5	130	19
20	40	36	10	M5	-	5,8	9	5,8	9	22	7	5,2	M5	8	-	20	15	25,5	12,7	8	5,7	5,7	5,7	38,5	10	-	4,5	150	28
25	44,5	40	10	M5	-	5,8	9	5,8	9	24,5	9	6	G 1/8	10,5	-	26	15,5	28	14	8	5,7	5,7	4,5	42	10	-	5,5	185	35,5
32	51	46	12	M6	24,5	5,8	9	-	-	27	9	-	G 1/8	11,5	36	32	-	-	-	10	5,7	-	4	48	12	5	11	282	39,5
40	58	55	12	M6	28	5,8	9	-	-	30,5	9,5	-	G 1/8	11	42	42	-	-	-	10	5,7	-	4	55	12	6	12,5	366	43,5
50	70	65	16	M8	34	6,8	11	-	-	37,5	12,5	-	G 1/8	11,5	50	50	-	-	-	13	6,8	-	4	65	12	6	13,5	521	68
63	86	80	16	M8	38,5	9	14	-	-	46	15	-	G 1/8	11	62	62	-	-	-	13	8,8	-	5	80	14	8	15	717	75
80	105	100	20	M10	44	9	14	-	-	55	14	-	G 1/4	14	82	82	-	-	-	17	9	-	6	100	15	10	18	1434	114
100	131	124	25	M12	56	11	17,2	-	-	69	17,5	-	G 1/4	16	103	103	-	-	-	22	11	-	7,5	124	20	10,5	20,5	2435	174

"H" DIMENSION

Ø	STROKE (mm)															
	5	10	15	20	25	30	40	50	60	80	100	125	160	200	250	
16	37	42	47	52	63	68	78	88	98	118	138	-	-	-	-	
20	37	42	47	52	63	68	78	88	98	118	138	163	-	-	-	
25	43,5	48,5	53,5	58,5	64,5	69,5	79,5	89,5	99,5	119,5	139,5	164,5	-	-	-	
32	44,5	49,5	54,5	59,5	64,5	69,5	79,5	89,5	99,5	119,5	139,5	164,5	199,5	-	-	
40	44,5	49,5	54,5	59,5	64,5	69,5	79,5	89,5	99,5	119,5	139,5	164,5	199,5	-	-	
50	-	49,5	54,5	59,5	64,5	69,5	79,5	89,5	99,5	119,5	139,5	164,5	199,5	239,5	-	
63	-	52	57	62	67	72	82	92	102	122	142	167	202	242	-	
80	-	56	61	66	71	76	86	96	106	126	146	171	206	246	296	
100	-	66	71	76	81	86	96	106	116	136	156	181	216	256	306	

NON ROTATING DOUBLE ACTING AND NON ROTATING DOUBLE ACTING MAGNETIC

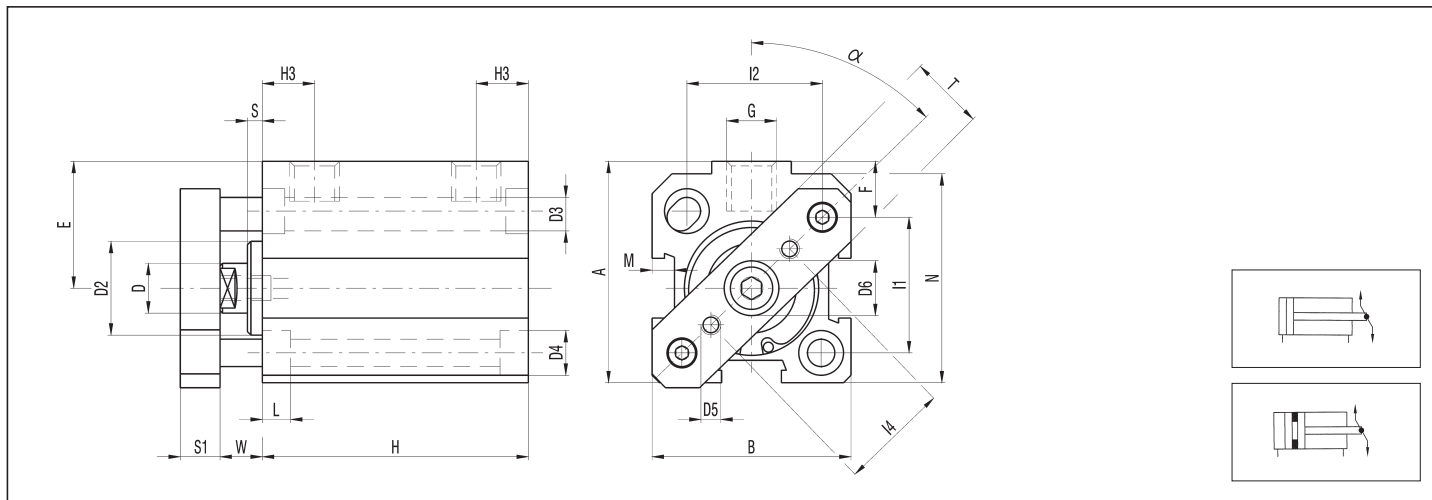

DIMENSIONS AND WEIGHTS

Ø	A	B	α	D	D2	D3	D4	D5	D6	E	F	G	H3	I1	I2	I4	L	M	N	S	S1	T	W	WEIGHT (g)	INCR. (g) x10 mm
20	40	36	45°	10	-	5,8	9,2	M4	11	22	9,3	M5	8	25,5	25,5	20	5,7	5,7	38,5	-	8	15	4,5	150	28
25	44,5	40	45°	10	-	5,8	9,2	M4	11	24,5	10,5	G1/8	11	28	28	22	5,7	4,5	42	-	8	15	5,5	185	35,5
32	51	46	41,5°	12	24,5	5,8	9,2	M5	17	27	9	G1/8	11,5	36	32	28	5,7	4	48	5	10	20	11	282	39,5
40	58	55	45°	12	28	5,8	9,2	M5	17	30,5	9,5	G1/8	11,5	42	42	33	5,7	4	55	6	10	20	12,5	366	43,5
50	70	65	45°	16	34	6,8	11	M6	22	37,5	12,5	G1/8	11,5	50	50	42	6,8	4	65	6	12	30	13,5	521	68
63	86	80	45°	16	38,5	9	14	M6	22	46	15	G1/8	12	62	62	50	8,8	5	80	8	12	30	15	717	75
80	105	100	45°	20	44	9	14	M8	28	55	14	G1/4	14	82	82	65	9	6	100	10	14	50	18	1434	114
100	131	124	45°	25	56	11	17,2	M10	30	69	17,5	G1/4	16	103	103	80	11	7,5	124	10,5	14	50	20,5	2435	174

"H" DIMENSION

Ø	STROKE (mm)													
	5	10	15	20	25	30	40	50	60	80	100	125	160	
20	37	42	47	52	63	68	78	88	98	118	138	-	-	
25	43,5	48,5	53,5	58,5	64,5	69,5	79,5	89,5	99,5	119,5	139,5	-	-	
32	44,5	49,5	54,5	59,5	64,5	69,5	79,5	89,5	99,5	119,5	139,5	-	-	
40	44,5	49,5	54,5	59,5	64,5	69,5	79,5	89,5	99,5	119,5	139,5	-	-	
50	-	49,5	54,5	59,5	64,5	69,5	79,5	89,5	99,5	119,5	139,5	164,5	-	
63	-	52	57	62	67	72	82	92	102	122	142	167	202	
80	-	56	61	66	71	76	86	96	106	126	146	171	206	
100	-	66	71	76	81	86	96	106	116	136	156	181	216	

MALE HINGE MOUNTING

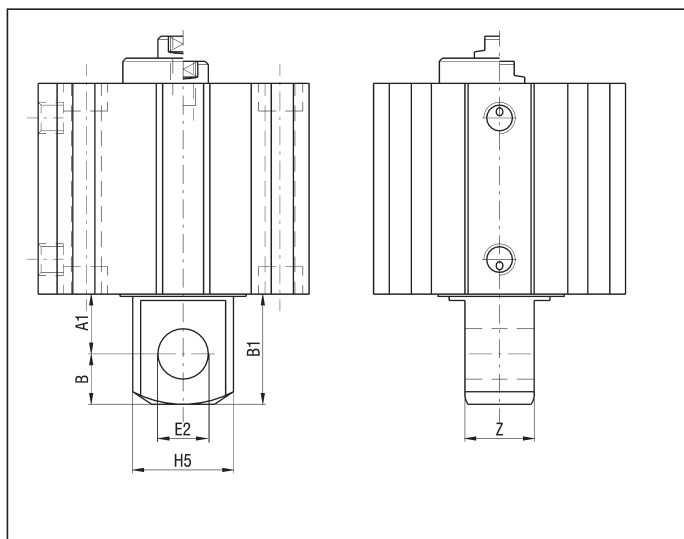

DIMENSIONS

Ø	A1	B	E2 H8	H5	Z	B1
16	8	6	6	12	7	14
20	10	8	8	16	9	18
25	10	8	8	16	9	18
32	13	10	10	20	14	23
40	15	12	12	24	16	27
50	15	12	12	24	17	27
63	19	16	16	32	22	35
80	19	16	16	32	22	35
100	23	20	20	40	26	43

1

FEET (pair) - ALUMINIUM - B/PB Ø

Ø	A2	B2	C	D9	E1	F2	I6
16	5	10	10	3,5	17	5	30
20	5	10	10	3,5	18	5	40
25	6	12	12	5,5	20	7,5	45
32	6	12	12	5,5	24	5	50
40	6	12	12	5,5	27,5	5	60
50	7,5	15	15	6,5	32,5	5	70
63	7,5	15	15	8,5	40	7,5	85
80	10	20	20	8,5	50	20	60
100	10	20	20	10,5	62	22	80

Ø	L2	M1	N1	R	WEIGHT (g)
16	H*+10	2,4	40	M3	10
20	H*+10	4	50	M5	10,1
25	H*+12	4	60	M5	20,4
32	H*+12	4	60	M5	20,4
40	H*+12	4	70	M5	24,7
50	H*+15	5	80	M6	44,7
63	H*+15	6,5	100	M8	53
80	H*+20	6,5	100	M8	99
100	H*+20	8	124	M10	120

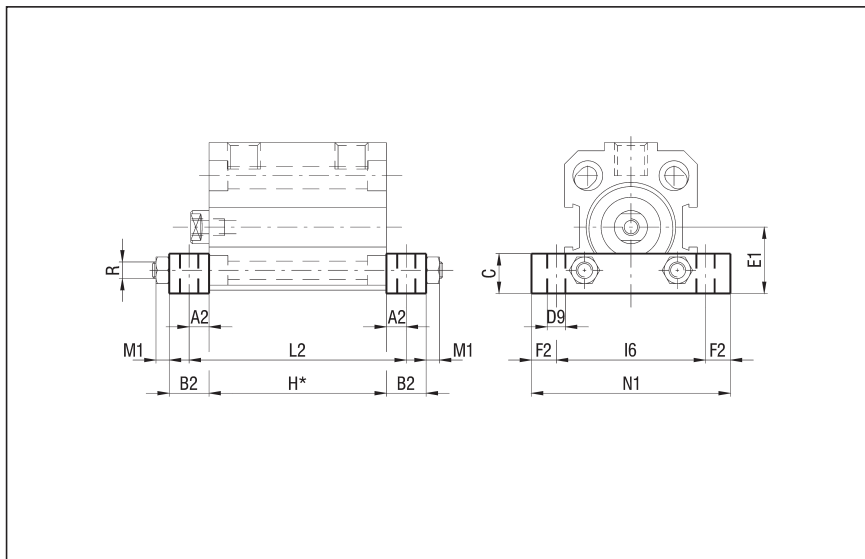

*DIMENSION "H" IS OBTAINABLE FROM THE TABLES OF THE SINGLE VERSION

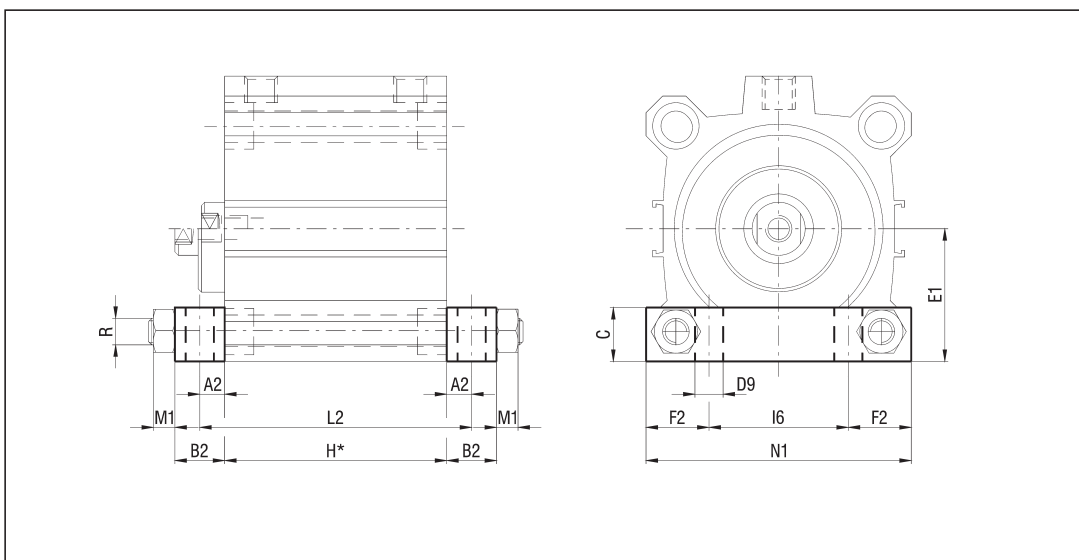

ROD NIPPLE WITH THREAD TO ISO STANDARD - STEEL - NB Ø

Ø	D	D1	A	B	C	WEIGHT (g)
12	M6	M3	16	6,5	22,5	3
16	M6	M4	15	8	23	3,2
20-25	M8	M5	20	10	30	7,2
32-40	M10x1,25	M6	22	12	34	13,1
50-63	M12x1,25	M8	24	14	38	23
G50-63	M16x1,5	M8	32	14	46	47,6
80	M16x1,5	M10	32	15	47	50,5
100	M20x1,5	M12	40	20	60	101

